

APF 15/40

FORWARD MOVING VIBRATORY PLATE



BROAD APPLICATION RANGE

The APF 15/40 is able to utilise key options to make this forward-moving plate extremely versatile. An optional Vulcolan mat, which can be installed without a single tool, provides quick adjustment when working with paving stones. A sprinkling system enables work on asphalt. The plate features a working width of 400 mm (15.7 in) and engine power of 2.6 kW (3.5 HP).

SIMPLE OPERATION

- Operator safety with low HAV levels (below 2.5 m/sec²)
- Machine frame that enables secure grip
- Great maneuverability boosts accuracy and makes work simple

POWERFUL COMPACTOR

- Generously sized, powerful exciter unit
- Leading compaction power, speed, climbing ability and machine life
- Compact dimensions allow use on sites with limited space

READY FOR RENTAL

- Low cost upkeep for owners
- Good match for many applications
- Easy for new users to operate

SERVICEABILITY

- Maintenance-free exciter system
- Full engine protection frame
- Toolless daily maintenance

VERSATILE OPTIONS

- Toolless mountable water tank and sprinkler system
- Toolless mountable rubber mats to change onto paving stones
- Permanently mounted transport wheels easy relocation of the machine on site

APPLICATIONS

- Compaction in confined areas
- Asphalt and paving applications
- Light to medium patchwork
- Pipeline and trench construction
- Landscaping and gardening
- Earthwork

AMMANN

TECHNICAL SPECIFICATIONS
APF 15/40 FORWARD MOVING VIBRATORY PLATE

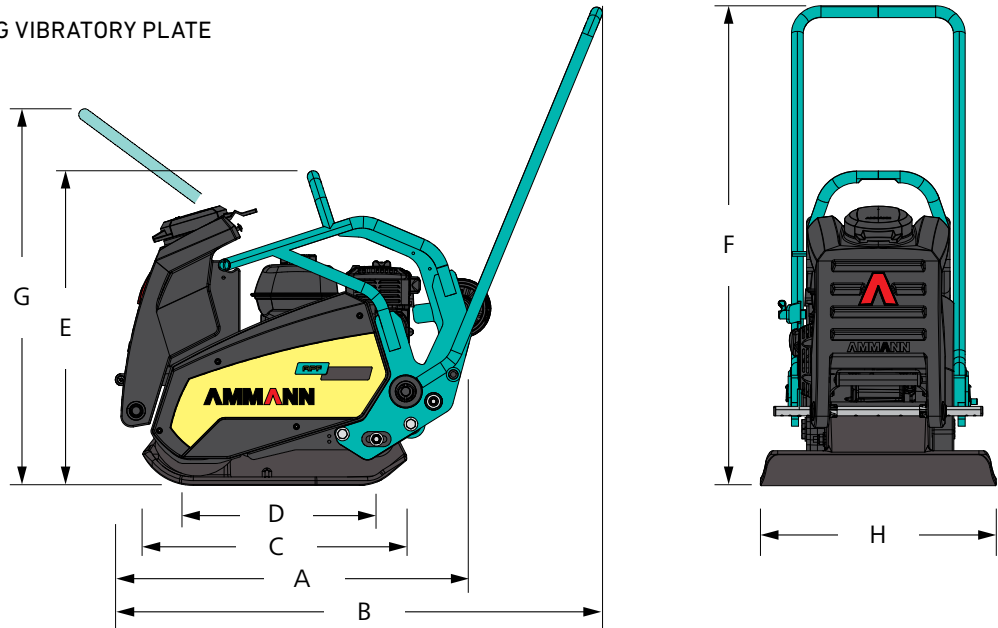

DIMENSIONS & WEIGHTS

MACHINE WEIGHT	80 kg (176 lb)
MACHINE WEIGHT (INCL. OPTIONAL SPRINKLER & WHEELS)	89 kg (195 lb)
A MACHINE LENGTH	700 mm (27.6 in)
B MACHINE LENGTH WITH HANDLE	1020 mm (40.2 in)
C BASE PLATE LENGTH	559 mm (22.0 in)
D GROUND CONTACT LENGTH	352 mm (13.9 in)
E MACHINE HEIGHT	667 mm (26.3 in)
F WITH HANDLE (WORK)	976 mm (38.4 in)
G WITH HANDLE (TRANSPORT)	736 mm (29.0 in)
H MACHINE WIDTH	400 mm (15.7 in)

COMPACTION FORCES

MAX. VIBRATION FREQUENCY	100 Hz (6000 vpm)
MAX. CENTRIFUGAL FORCE	15 kN (3372 lbf)
WORKING SURFACE	648 m ² /h (6975 ft ² /h)
SPEC. SURFACE PRESSURE	10.7 N/cm ² (15.5 psi)

ENGINE

ENGINE	Honda GX 120
FUEL	Petrol
ENGINE OUTPUT AT RPM	2.6 kW (3.5 HP) 3600

MISCELLANEOUS

HAND-ARM VIBRATION ON HANDLE	<2.5 m/s ²
SPEED	0-27 m/min (0-88.6 ft/min)
GRADEABILITY	30 %
MAX. INCLINE TO ALL SIDES	20°

OPTIONS

RUBBER MAT	x
TRANSPORT WHEELS	x
WATER SPRINKLER SYSTEM	12 l (3.2 gal)
HOUR METER	x

HIGHLIGHTS

- Low-vibration handle for operator safety and comfort
- Maintenance-free exciter system
- Base plate that is self cleaning and wear resistant
- Engine frame for protection on the jobsite and during transport
- Transport wheels, which can be dropped with a foot release and enable mobility on the jobsite